

Voluntary Timing and Brain Function: An Information Processing Approach

Alan M. Wing

*Behavioural Brain Sciences Centre, School of Psychology, The University of Birmingham,
Edgbaston, Birmingham B15 2TT, United Kingdom*

Published online October 29, 2001

This article takes an information processing perspective to review current understanding of brain mechanisms of human voluntary timing. Theoretical accounts of timing of the production of isochronous tapping and rhythms and of bimanual responding repetitive responding are reviewed. The mapping of higher level temporal parameter setting and memory processes and of lower level motor implementation process onto cortical and subcortical brain structures is discussed in relation to evidence from selective lesions in a range of neurological motor disorders. Brain activation studies that have helped identify key brain structures involved in the control of timing are reviewed. © 2001 Elsevier Science

1. INTRODUCTION

Variability is characteristic of the timing of movement. Even a skilled drummer is likely to exhibit moment-to-moment fluctuation in intervals between drum beats. Of course, some departures from strict periodicity are desirable when they contribute to the expressiveness of musical performance (Shaffer, 1982). However, some unintended variation from the notated durations is to be expected. Such variability reflects limits on voluntary timing and, in this brief review, I consider the nature of the variability and the brain mechanisms that may be involved. I summarize the literature on control of timing in terms of behavioral studies of normal and neurologically impaired subjects, and studies of brain activation. Questions addressed include: What is the nature of variation in timing? What is the relation between mean and variance of interresponse intervals? How do successive intervals covary? What roles are played in timing by cognitive processes such as memory and attention? What are the links between time interval production and the perception of time intervals? What is the difference between simple tapping and producing rhythmic patterns of time intervals? What is the relation between timing one or two hands? What do the various brain structures involved in movement contribute to timing? Do different neurological motor disorders result in contrasting patterns of impaired timing?

2. TWO-LEVEL MODEL OF SOURCES OF VARIABILITY IN TIMING

In this review I focus on behavioral studies of timing of relatively short intervals of up to 2 or 3 s, since these span the timescale of (and may therefore be applicable

The research for the preparation of this article was funded by the MRC.

Address correspondence and reprint requests to Alan Wing, University of Birmingham, Behavioural Brain Sciences Centre, School of Psychology, Edgbaston, Birmingham B15 2TT, UK. E-mail: a.m.wing@bham.ac.uk.

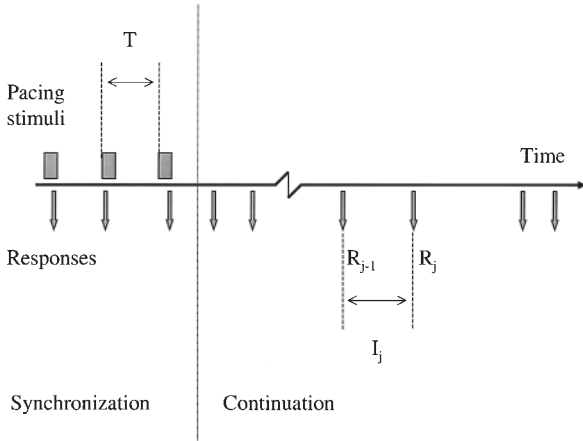

FIG. 1. Synchronization–continuation paradigm for studying response timing. Each trial begins with a number of pacing stimuli, spaced T ms apart, with which the subject attempts to synchronize. This is followed by an unpaced phase in which the subject is required to continue responding at the same rate, so the continuation interresponse intervals reproduce the target interval.

to) voluntary movements in everyday actions as well as in communicative acts such as speech and music. Whether timing intervals in the range 200 to 2000 ms involve similar mechanisms to timing intervals, say, 50 times longer or more, is an open question (Gibbon, Malapani, Dale, & Gallistel, 1997). But certainly the paradigms differ, with research on longer intervals focusing on single-interval production whereas short-interval timing is often studied in the context of rhythmic tapping.

A frequently used paradigm under the short-interval timing heading, introduced by Stevens (1886), involves repetitive responding to produce a series of interresponse intervals I_j (see Fig. 1). Experimental control over $\text{mean}(I)$ is obtained by including, at the beginning of each trial, a paced responding phase in which the subject synchronizes responses with an auditory pulse train whose interpulse interval is set to the target interval, T . When the pulses stop the subject is instructed to continue at the same rate for a further 30 to 50 responses. During the unpaced phase it is found that subjects maintain $\text{mean}(I)$ within a few milliseconds of T , but with variability $\text{var}(I)$ that increases with $\text{mean}(I)$ (Wing and Kristofferson, 1973a).

A key characteristic of unpaced responding is that successive intervals I_j, I_{j+1} are negatively correlated between zero and minus one-half. A theoretical account was proposed by Wing and Kristofferson (1973b). They suggested a hierarchical two-level model (see Fig. 2) in which the response triggered by a central timer at the end of each internally generated interval C_j is subject to a delay in motor implementation M_j before the occurrence of an observable response. If, over successive responses, $j = 1, 2, \dots, N$, the C_j are independent of the M_j , and both are random variables, the I_j have variance:

$$\text{var}(I) = \text{var}(C) + 2\text{var}(M). \quad (1)$$

The model predicts dependence between adjacent $I_j I_{j+1}$ with lag-one autocovariance:

$$\text{acov}(I(1)) = -\text{var}(M). \quad (2)$$

This results in the following prediction for the autocorrelation at lag k :

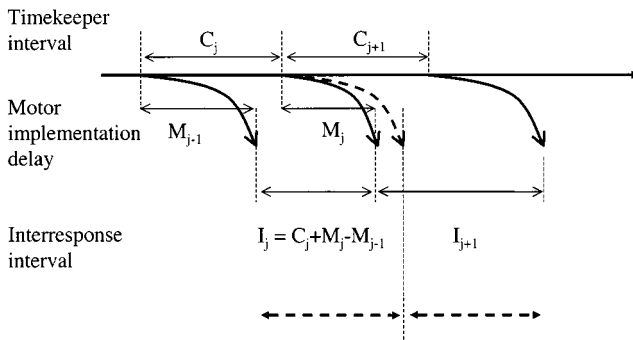

FIG. 2. Wing–Kristofferson two-level timing model. Timekeeper intervals (C) are subject to motor implementation delays (M) in defining interresponse intervals (I). Average I is equal to the average C . However, variation in I reflects both C and M . In particular, variation in M results in negatively correlated I (tendency for short and long intervals to alternate), as suggested by the dashed lines.

$$\begin{aligned}
 \text{acorr}(I(k)) &= \text{acov}(I(k))/\text{var}(I) \\
 &= -1/\{2 + \{\text{var}(C)/\text{var}(M)\} \} & k = 0 \\
 &= 0 & k > 0
 \end{aligned} \tag{3}$$

From Eq. (3) it can be seen that the Wing–Kristofferson (WK) model predicts that the lag-one autocorrelation (the correlation between adjacent pairs of intervals taken through the sequence of intervals) should be bounded by zero and minus one-half. The autocorrelation at higher lags is predicted to be equal to zero, $\text{acorr}(I(k)) = 0$, $k > 1$. This has been reported to be the case in a number of studies, including not only finger movements but also speech and eye movements (see Tables 1 and 2).

A number of repetitive timing studies have reported lag-one autocorrelation estimates outside the range predicted by the WK model. Such departures on individual trials might represent statistical fluctuation for which the appropriate approach is to take the mean over repeated trials. However, if the mean over a series of trials reveals systematic divergence from the model predictions, it may indicate failure of the model's independence assumptions. Thus, Wing (1977) suggested that persistent negative correlation at lags greater than one reflects autoregressive dependence in the motor implementation delays. However, Wing (1979) subsequently noted the possibility of another factor contributing to apparent violations of the model, namely that autocorrelation estimators are biased when sequences are relatively short. Bias reduces with longer sequences, but requiring subjects to tap for longer might have the undesirable effect of introducing drift, which would introduce an overall positive effect on autocorrelation at all lags (Madison, in press). Although this could be corrected by detrending procedures, these introduce other biases, so it could be argued that a better approach is to stay with relatively short sequences and make explicit allowance for estimator bias (see Vorberg & Wing, 1996).

Equations (1) and (2) can be solved to yield estimators for $\text{var}(C)$ and $\text{var}(M)$. It is interesting to determine whether the underlying timekeeper and motor implementation processes, assumed to be distinct and producing intervals that are mutually independent, are behaviorally dissociable. That is to say, are there experimental factors whose effect on timing behavior can be shown to affect just one of the variance components leaving the other unaffected? One such factor might be expected to be the interval produced between responses. As long as subjects produce responses in the same manner, lengthening the interval to be produced might be expected to selec-

TABLE 1
Wing-Kristofferson Model in Normal Studies of Repetitive Timing^a

Ref.	Movement; manipulandum	<i>T</i> (ms)	Accorr(I(1))	Var(<i>C</i>) (ms ²)	Var(<i>M</i>) (ms ²)	Comment
1	Wrist; Morse key	180 to 400	-0.43 to -0.10	90	40	Linear functions for increase in var(<i>C</i>) with <i>T</i> had negative intercepts
2	Finger; touch key press (P) and release (R) times	400	X	X	P: 120 R: 150	Key release intervals more variable than press intervals; but release not hierarchically triggered by key press
3	Finger; touch key	220 to 490	X	280 (<i>SD</i>)	25 (<i>SD</i>)	Functions showing linear increase in var(<i>C</i>) with <i>T</i> had negative intercepts
4	Finger; computer key- board	550	<0 on 78% trials	10 years: 28 7 years: 41 (<i>SD</i>)	15 16	Reliable decrease in var(<i>C</i>) in 10-year-olds; var(<i>C</i>) (but not var(<i>M</i>)) greater in clumsy children
5	Finger; computer key- board	550	<0 on 98% trials	6 years: 42 9 years: 29 21 years: 15 43 years: 18 67 years: 23 (<i>SD</i>)	9 12 8 10 10	Children and older adults reliably greater var(<i>C</i>); males reliably lower var(<i>C</i>) than females (no interaction with age); no differences in var(<i>M</i>)
6	Finger; microswitch	400	X	350	100	Simultaneous solving of anagrams increased var(<i>C</i>) but not var(<i>M</i>)
7	Finger; lever on microswitch	325 to 550	X	250	50	Included demonstration of parallel increase in variability of time perception and var(<i>C</i>)
8	Finger; touch key	200 to 640	-0.30 to -0.02	(<i>SD</i>) 11	(<i>SD</i>) 5	Included analysis of synchronization phase

Note: (1) Wing & Kristofferson (1973b); (2) Wing (1980a); (3) Wing (1980b); (4) Williams, Woolacott, & Ivry, 1992; (5) Greene & Williams (1993); (6) Sergeant et al. (1993); (7) Ivry & Hazeltine (1995); (8) Semjen, Schulze, & Vorberg (2000).

^a Where a range of intervals was tested the single values indicate means observed in the middle of the target interval range. X signifies no estimate reported.

TABLE 2
Effect of Using Different Effectors on Wing-Kristofferson Model of Repetitive Timing^a

Ref.	Movement; manipulandum	T (ms)	Acorr(I(1))	Var(C) (ms ²)	Var(M) (ms ²)	Comment
1	Finger (F); wrist (W); arm pronation (AP); arm elevation (AE); touch key	400	X	F: 300 W: 220 AP: 150 AE: 150	140 80 80 60	For model with correlated (+0.4) response delays, revised estimates were var(C) 80–90 ms ² , var(M) 140–340 ms ²
2	Speech (Sp); finger (F); voice key; microswitch	400	-1/2 < Acorr(I(1)) <0 on 80% trials	(SD) Sp: 10 F: 11	(SD) 10 9	Included bimanual (var(C) less than unimanual) and bimodal (var(M) more than unimodal) conditions
3	Speech (Sp); jaw (J); wrist (W); forearm (F); strain gauge to lip, microswitch	400	X	J: 8685 Sp: 7840 W: 717 F: 540	(-1369) (-703) 145 134	Individual differences: Var(C) positively correlated across tasks (except nonsig. between W, F)
4	Horizontal saccadic eye movement; intervals between medial-lateral direction reversals	500, 700, 1000	-1/2 < Acorr(I(1)) <0 on 84% trials	(SD) 40 to 75	(SD) 30 to 60	Var(C) and var(M) both increase with interval

Note. Refs. (1) Wing (1977); (2) Hulstijn et al. (1992); (3) Franz, Zelaznik, & Smith (1992); (4) Collins, Jahanshahi, & Barnes (1998).

^a X indicates no values reported.

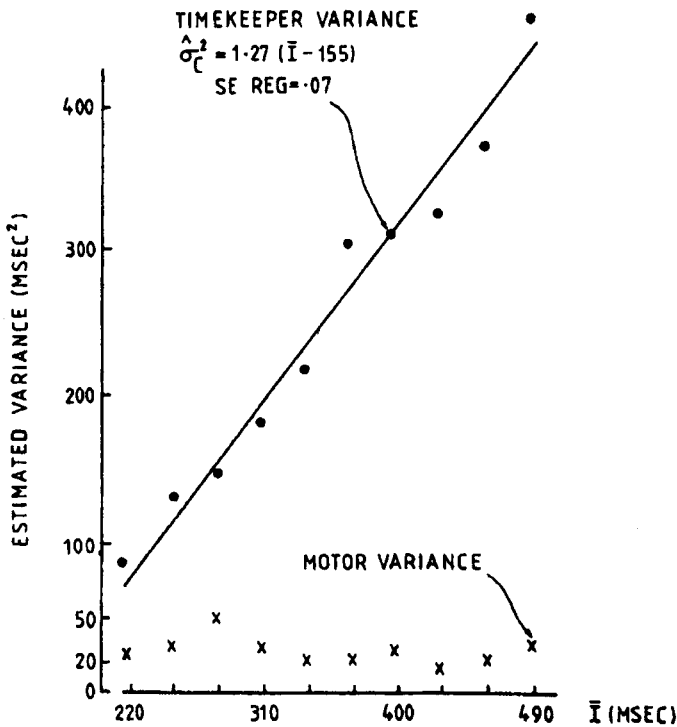

FIG. 3. Variability of timing. At longer intervals, timekeeper variance ($\text{var}(C)$) increases but motor implementation variance ($\text{var}(M)$) is relatively constant. (From Wing, 1980.)

tively increase timekeeper variance. Wing (1980a) showed that this was the case in an experiment in which subjects tapped to different target intervals, T , in the range 220–490 ms on different trials (see Fig. 3). Tables 1 and 2 summarize a number of other experiments partitioning timing variability into $\text{var}(C)$ and $\text{var}(M)$.

It is instructive to relate the partitioning of variability of timing into timekeeper and motor implementation variance in repetitive responding to measures of timing variability reported in a single interval production task studied by Rosenbaum and Patashnik (1980a, 1980b). Subjects used R and L index finger responses to delimit a single interresponse interval, I , to match a previously presented target, T . This was varied in steps of 100 ms up to 1000 ms, with the shortest, $T = 0$ ms, requiring simultaneous movement of the index fingers. Instructions in different blocks of trials emphasized either speed (produce the first response as quickly as possible) or accuracy (produce the interval as accurately as possible). As would be expected, reaction time (RT) was faster in the speed condition. RT was also faster with larger values of T . Later, we return to consider these RT effects, but here we focus on the interval timing results. In both speed and accuracy conditions mean(I) matched the target. For $T = 0$ ms the variances were nonzero and equal in the two conditions. At larger values of T , $\text{var}(I)$ increased linearly with mean(I). The slope of the function relating mean and variance of the intervals between left- and right-hand responses was less steep in the accuracy condition than in the speeded condition (see Fig. 4).

There are two points to note arising from the results on variability of the time intervals produced in this task. First, in the condition calling for simultaneous responses, the variability $\text{var}(I)$ may be attributed to the motor system, since there is no demand on timing ($T = 0$). It is thus reassuring to note that Rosenbaum and Patashnik reported equal intercepts (no difference in the variability at zero interval)

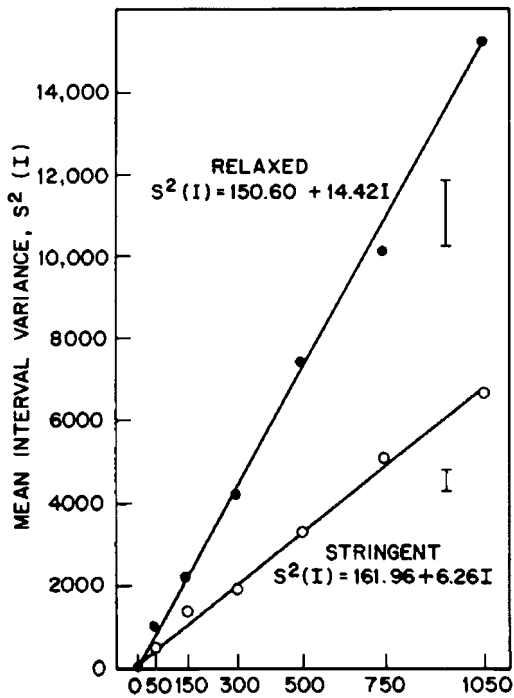

FIG. 4. Instructions to be more accurate in producing a pair of timed responses reduce the slope of the variance function but leave the intercept unaffected. (From Rosenbaum & Patashnik, 1980b.)

for the speed and accuracy conditions. Second, assuming that motor variability is constant as mean(I) increases, which is plausible given the fixed nature of the key press response, the change observed in $\text{var}(I)$ may be identified with the timer. In Rosenbaum and Patashnik's data the timer variance increased linearly with the mean. Other studies using different paradigms (e.g., Treisman, 1963) have reported that standard deviation (SD) increases linearly with mean. Ivry and Corcos (1993) have commented that, in general, there may be little to choose between the linear increase in variance and linear increase in SD in terms of the fit of either function to the data. Moreover, they observed that, for some sets of data (e.g., Wing, 1980a, but not Rosenbaum & Patashnik, 1980a, 1980b), the function linear in SD gives a positive intercept (at $T = 0$) whereas, for variance, the intercept is less than zero. A positive intercept has a clear interpretation in terms of irreducible variability in the system, whereas a negative intercept, suggesting variance is less than zero at $T = 0$, is obviously problematic. Hence, in the general case, it seems more appropriate to choose a quadratic form for the function relating mean and variability of timing.

3. MOTOR DISORDER AND TIMING

Timing is often found to be more variable in neurological motor disorders than in normal controls. The two-level Wing-Kristofferson timing model has been applied in a number of neuropsychological studies of the effects of motor disorder on timing (see Table 3) in order to determine whether increase in $\text{var}(I)$ should be attributed to central or peripheral factors. For example, Wing, Keele, and Margolin (1984) reported a case study of Parkinson's disease (a disorder affecting basal ganglia function, see Fig. 5) in which the clinical problems were limited to one side of the body—

TABLE 3
Wing-Kristofferson Model in Neuropsychological Studies of Repetitive Timing^a

Ref.	Movement; manipulandum	Subjects	T (ms)	Accor(I(1))	Var(C) (ms ²)	Var(M) (ms ²)	Comment
1	Index finger; touch plate	Case study; Parkinsons; right (RH) vs left (FH) hand	450, 550	X	RH: 2375 LH: 775 (SD)	225	The more bradykinetic hand showed increased var(C) on later repeat testing
2	Index finger; microswitch	Cortical stroke (CS); cerebellar (C); Parkinsons (P); neuropathy (N); controls (Con)	550	X	CS: 29 C: 35 P: 27 N: 23 Con: 24 (SD)	225 (SD) 20 18 10 17 13	Time perception and Var(C) elevated only in C; var(M) elevated in C and Cs compared to controls (Con)
3	As (3)	Cerebellar: lateral (L); medial (M)	550	X	L:31 to 47 M:20 to 33 P: 2467 C: 83	10 to 26 20 to 32 P: 446 C: 28	Var(C) elevated in lateral lesions; var(M) in medial lesions
4	Alternating wrist flex, extend; flex onset intervals	Parkinsons (P); controls (C)	400 to 2000	-1/2 < Accor(I(1)) < 0 in 30-60% subjects			Both var(C) and var(M) elevated in Parkinsons
5	Finger; keypad key	Alzheimer (A); Parkinsons (P); college (C); elderly (E)	550	-1/2 < Accor(I(1)) < 0 in 54-88% subjects	(SD) A: 28 P: 24 C: 24 E: 21 (SD)	(SD) 12 10 11 14	Only A show sig. differences in var(C) (not var(M))
6	Finger; touch (infrared beam)	Parkinsons: off (F) vs on (N); worse (W) vs better (B) hand; controls (C)	550	-1/2 < Accor(I(1)) < 0 in 70% subjects	C: 15 F:24 N:18 W:24 B:18 (SD)	8 13 8 12 8	Var(C) and var(M) both elevated in off (F) vs on (N) and controls (C) and in worse compared to better hand
7	Index finger; microswitch; unilateral vs bilateral	Cerebellar; unimpaired (U), impaired (I) hand	400	X	U: 14 vs 12 I: 21 vs 15 CH: 777 C: 1112	(SD) 10 vs 10 12 vs 12 475 106	Var(C) elevated in I. Lower variability in bimanual tapping due to reduction in var(C) CH has cerebellar consequences; Var(M) but not var(C) elevated compared to controls
8	Finger; touch key	Congenital hypothyroidism (CH); controls (C)	540	<0 for 69% subjects			
9	Finger; unspecified	Parkinsons (P); controls (C)	300, 600	X	(SD) P: 27, 42 C: 19, 28	(SD) 14, 21 12, 16	Time perception impaired and var(C) (not var(M)) elevated in Parkinsons

Note: (1) Wing et al. (1984); (2) Ivry & Keele (1989); (3) Ivry et al. (1988); (4) Pastor et al. (1992); (5) Duchek, Balota, & Ferraro (1994); (6) O'Boyle et al. (1996); (7) Franz et al. (1996); (8) Kooistra, Snijders, Schellekens, Kalverboer, & Geuze (1997); (9) Harrington et al. (1998a).
^a X indicates no values reported.

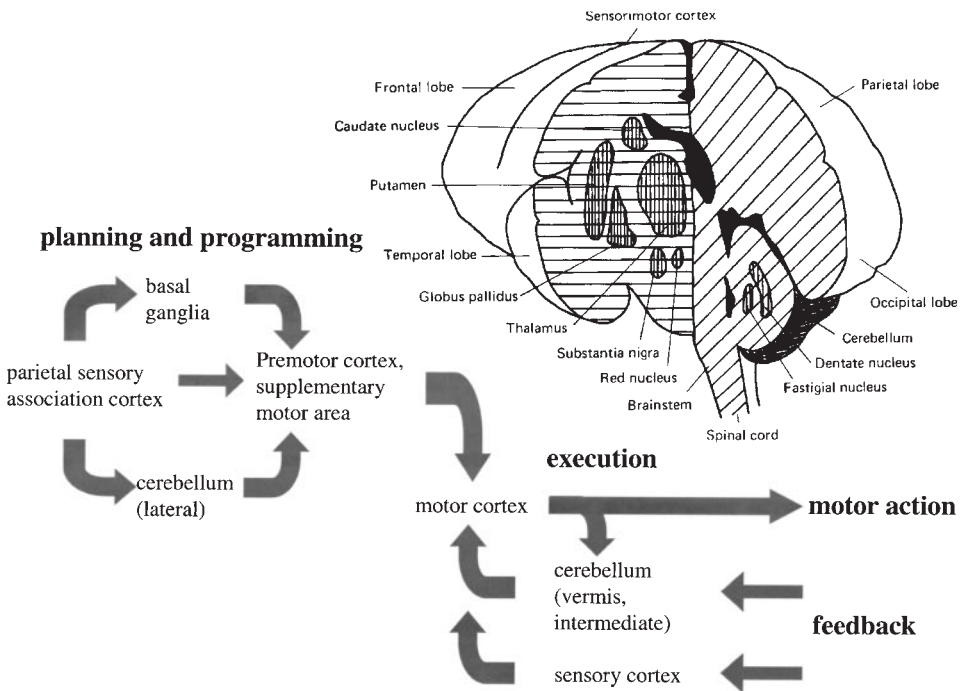

FIG. 5. Schematic showing the motor system of the brain, including frontal lobe (premotor cortex, supplementary motor area), sensorimotor cortex, basal ganglia (caudate nucleus, putamen, globus pallidus, substantia nigra), and cerebellum, and hypothesized relations with movement preparation and execution. (Adapted from Smyth & Wing, 1984.)

hemiparkinsonism. Lateralized increase in $\text{var}(I)$ was observed and found to be due to elevated $\text{var}(C)$, suggesting the involvement of the basal ganglia in timekeeping.

In a series of case studies of patients with cerebellar disorders, Ivry, Keele, and Diener (1988) identified elevated $\text{var}(I)$ with increased $\text{var}(C)$ in patients who had lesions of the dentate nucleus (the output of the lateral cerebellum). In contrast, in patients who had medial cerebellar lesions, raised $\text{var}(I)$ was due to elevated $\text{var}(M)$. In a second study (Ivry & Keele, 89) response timing was compared in patients with cerebellar lesions, Parkinson's disease, or hemiparesis due to cortical stroke. Within-patient comparisons showed increased $\text{var}(I)$ on the more impaired side, but when this variance was partitioned into $\text{var}(C)$ and $\text{var}(M)$, there was no clear distinction between patient groups. Duration discrimination was also tested and, because performance was only impaired in the cerebellar patients, it was argued that the cerebellum was special in being involved in timing functions common to performance and perception.

A common anatomical substrate would explain why there are correlations seen between response timing and time perception in normal subjects (Ivry & Hazeltine, 1995; Keele, Pokorny, Corcos, & Ivry, 1985). However, that substrate may not be limited to the cerebellum. Thus, various studies (reviewed in O'Boyle, 1997) have shown impaired response timing and duration discrimination in Parkinson's disease. In some cases (Pastor, Jahanshahi, Artieda, & Obeso, 1992; O'Boyle, Freeman, & Cody, 1996) the Wing-Kristofferson model failed to show differential effects of the disorder on $\text{var}(C)$ and $\text{var}(M)$. In contrast, Harrington and colleagues (Harrington & Haaland, 1998; Harrington, Haaland, & Hermanowicz, 1998a) reported a selective increase in $\text{var}(C)$ in Parkinson's disease. Thus, neuropsychological data do not, at

present, distinguish unequivocally between basal ganglia and cerebellar contributions to timekeeping and motor implementation. Moreover, both neural structures may contribute to common timekeeping functions in time interval production and perception.

4. SYNCHRONIZATION

Studies of timing have used both unpaced and paced tapping. It could be argued that paced responding is more complex than unpaced tapping since subjects must both produce intervals and correct them according to perceived error in phase or period. With first-order linear correction (see Fig. 6), such that the current timer interval is adjusted in proportion to the preceding discrepancy between the times of response and pacing stimulus, phase can be maintained even with an inaccurately set timer. However, $\text{var}(I)$ increases with the strength of the correction factor and, more generally, the interresponse interval autocovariance function, $\text{acov}(I(k))$, depends on the correction factor (Vorberg & Wing, 1996; see Fig. 7). That is, in synchronization the behavior of $\text{acov}(I(k))$ reflects an interaction between feedback control adjustments and the nature of the motor execution processes (see also Pressing, 1999). The autocovariance function is simpler, and its interpretation is easier, if consideration is restricted to unpaced responding.

Although $\text{acov}(I)$ may be simpler to interpret in unpaced than in paced responding, unpaced responding may not be cognitively less demanding than synchronization. The withdrawal of the external standard, T , at the end of synchronization, may mean that, in unpaced responding, there is a greater cognitive demand due to the need to remember the target interval. A brain activation (fMR) study of 18-s periods of paced followed by unpaced responding (Rao et al., 1997) suggests that the two modes of tapping involve partially separated networks in the brain, with the network for continuation including that for synchronization as a subset. Scans, obtained from subjects tapping with the right hand (T set at 300 or 600 ms), showed activation in R cerebellum, L sensorimotor cortex, and R superior temporal gyrus in both paced and unpaced phases of the task. In addition, during unpaced, but not during paced, responding, activation of R inferior frontal gyrus with supplementary motor area (SMA), putamen, and VL thalamus was observed. These results led to the suggestion of a contrast between implicit timing, in keeping pace with the metronome, and explicit timing, in continuation. Rao et al. suggested that the latter involves additional processes to sustain a working memory representation of T , based on R inferior frontal gyrus linked to R superior temporal gyrus, plus explicit timing control based on SMA, putamen, and VL thalamus.

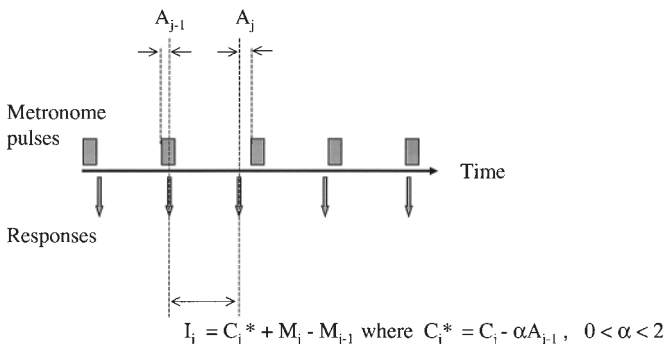

FIG. 6. Synchronization using first-order correction of the timekeeper interval based on the immediately preceding asynchrony of response and metronome pulse.

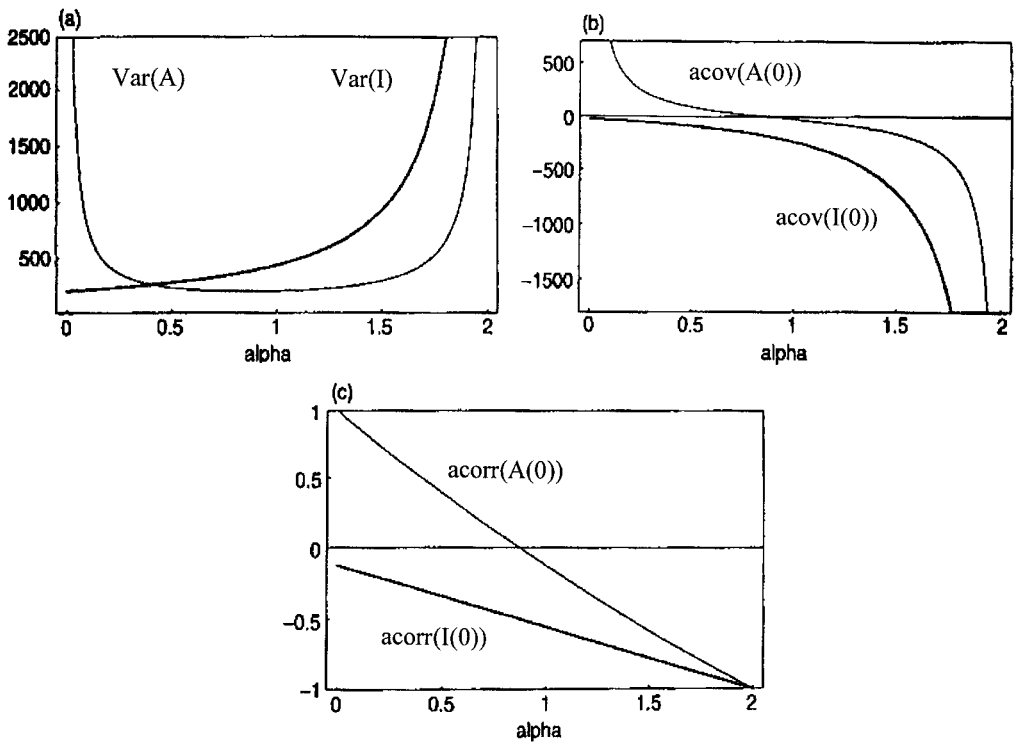

FIG. 7. Effects of varying degree of synchronization correction (α , alpha) on variances (top left), lag-one autocovariances (top right), and lag-one autocorrelations (bottom) of asynchronies and interresponse intervals. (From Vorberg & Wing, 1996.)

5. WORKING MEMORY IN TIMING

Performing other tasks simultaneously with timing increases interresponse interval variability. For example, silent counting backward in threes during unpaced tapping increases $\text{var}(I)$ (Wing, 1990). Sergent, Hellige, and Cherry (1993) analyzed the effects of concurrent anagram solving on timing in terms of the two-level timing model and found the secondary task increased $\text{var}(C)$, leaving $\text{var}(M)$ unchanged. One possible reason for selective central interference is that memory processes for timing are affected by performance of a concurrent task (Inhoff & Bisiacchi, 1990; Saito & Ishio, 1998). A theoretical account of memory processes in central timing was provided by Gibbon, Church, and Meek (1984), based on the work of Creelman (1962) and Treisman (1963). Gibbon et al. assumed that timekeeping is based on pacemaker pulses gated into an accumulator with a count being compared against a target value maintained in a reference memory to determine when a response should be made (see Fig. 8). From this perspective impaired timing during simultaneous performance of another task might result from disturbances to reference memory or disruption of the gating process (Zakay & Bloch, 1996).

Counting pacemaker pulses can serve time interval perception in addition to the production of time intervals. Consider the discrimination of two time intervals; if a count is taken of the number of pulses occurring in each interval, their duration may be compared on the basis of a difference in counts. The assumed nature of the pulse source has implications for performance in both time perception and production tasks. For example, in the case of time interval discrimination, Creelman (1962) suggested that increases in threshold for discrimination at longer intervals reflect randomness

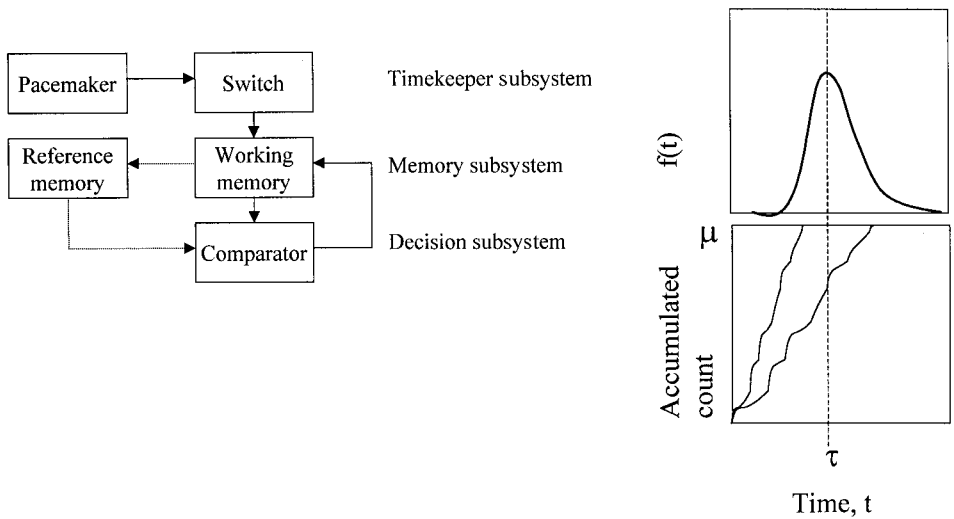

FIG. 8. Pacemaker-counter model of timing. (Left) A random event source provides a count which is cumulated in working memory and compared with a previously stored target value in reference memory. (Lower right) The time τ taken to accumulate the count μ varies from one trial to the next. (Upper right) Over trials, this results in a distribution $f(t)$ of produced time intervals. (Adapted from Gibbon et al., 1984.)

in the pulse source. He assumed a Poisson pulse source, in which case the variance in the number of pulses obtained for a given duration increases linearly with duration. In the case of time interval production tasks, a Poisson source results in variability in the time to attain a given count that increases linearly with the count. Miall (1996) described simulations of a neural network in which a large number of neurons, each neuron firing with constant low probability per unit time, gave an integrated output that provided a time measure. He commented that there would be no clues to the timing function of the ensemble of neurons from recording of the activity of an individual neuron. It is therefore interesting to note that Macar, Vidal, and Casini (1999) obtained EEG recordings (reflecting ensemble activity) which suggested that SMA may participate in (or receive input from) a pulse accumulation process in both time interval production and perception tasks.

Poisson-based counting accords with the linear increase in $\text{var}(I)$ with $\text{mean}(I)$ observed by Rosenbaum and Patashnik (1980a, 1980b). In their study, the instruction to be more accurate resulted in a reduction in variance, but only through a reduction in slope and not in intercept. This finding is also consistent with Poisson timing if it is assumed the pulse rate increases in the more accurate condition. Recall that RT was slower in the accuracy condition. Perhaps the slowing reflects setting a higher than normal pulse rate and rescaling the relation between target count and required interval (Treisman, Faulkner, Naish, & Brogan, 1990, used the term calibration for scaling operations of this kind). However, this suggestion does not explain Rosenbaum and Patashnik's observation that RT decreased with longer intervals (regardless of accuracy). This finding might relate to motor execution processes, with longer RT at short intervals reflecting a need to prepare two movements in advance. When producing longer intervals the interresponse interval may provide sufficient time to prepare the second response after the second one has been initiated. In the latter case, the RT reflects the (shorter) time to prepare just the first response.

We have already noted the debate over the form of the increase in variability of intervals with the mean and the suggestion that the function is linear in SD rather than variance (Ivry & Corcos, 1993). That is, $\text{var}(I)$ tends to increase more rapidly

than mean(I). In the counter model, one possible explanation of this is that there is another source of time-dependent variance in addition to the variance in the pulse source. Gibbon (1992) suggested that this might be a multiplicative, or scaling, operation associated with encoding and retrieval of count-based representations of time. If a multiplicative operation introduces a random element to the value for the target pulse count, a linear increase in standard deviation with mean interval is predicted over most of the range of the intervals produces. However, at the shortest intervals before the scaling effect dominates, Poisson-based variance results in a linear increase in variance.

Earlier it was noted that cerebellar patients exhibit not only impaired movement but also impaired time perception (Ivry & Keele, 1989). An effect of impaired auditory working memory on time perception was indicated by a study of neurological patients with frontal lesions (Mangels, Ivry, & Shimuzu, 1998). Duration discrimination at base intervals of 400 and 4000 ms and frequency discrimination were evaluated in a group of frontal patients and in a comparison group of patients with cerebellar lesions. As would be expected from the Ivry and Keele (1989) study, the cerebellar patients were impaired on time discrimination at both intervals. In contrast, frontal patients were impaired only at the longer interval. Moreover, the frontal group, but not the cerebellar group, also had impaired frequency discrimination when standard and comparison were separated by 4000 ms compared to 400 ms. Mangels et al. (1998) suggested that the problem common to duration and auditory discrimination tasks in the frontal group was not timing per se but the delay, which exposed a working memory limitation.

In their report Mangels et al. (1998) noted an alternative interpretation that the impairment in the frontal group might reflect an attentional deficit in the case of the longer delay. For example, a tendency to inattention that increases with time could result in impaired sensory registration of the second stimulus after the longer interval. It is therefore interesting that Harrington, Haaland, and Knight (1998b) observed impaired duration discrimination (around intervals of 300 and 600 ms) associated with attention deficits in patients with right cortical damage. Their study included patients with left- as well as right-hemisphere damage and both groups exhibited impaired duration discrimination performance. However, when patients were selected so that left- and right-hemisphere groups were matched for their ability to perform an auditory pitch discrimination task, impaired duration discrimination was restricted to the right-hemisphere group. Moreover, only this group showed impaired performance on an attention switching task, suggesting the importance of attentional factors in duration discrimination.

Further evidence of a contribution of frontal cortex to memory aspects of motor timing comes from brain activation studies. In a PET study of self-initiated vs externally triggered actions (auditory signals to respond occurred at the same intervals as those produced in the self-initiated condition), Jahanshahi et al. (1995) showed that the major difference in activation was in dorsal prefrontal cortex in the self-initiated condition. The latter required subjects to vary the time randomly around a mean of 3400 ms. It is likely that the difference in activation reflected the need to refer to memory for previously produced times in the self-initiated condition, since previous work (Petrides, Alvisatos, Evans, & Meyer, 1993) has shown that dorsal prefrontal cortex is activated when subjects hold past responses in memory and regulate their responses on this basis.

6. RHYTHM

The WK two-level model of timing has been extended to provide a psychological account of rhythm production. Western music is frequently organized into rhythmic

figures that follow hierarchical rules (Martin, 1972). Thus bars are subdivided into beats that may be further subdivided into simple fractions of the beat. This led Vorberg and Hambuch (1978) to suggest that the production of rhythms involves separate timers working at a number of levels in a hierarchy (see Fig. 9). Assuming that variability at each level is independent of variability at other levels leads to a prediction of negative correlation, $\text{corr}(I_j, I_{j+k}) < 0$, not only for $k = 1$ (as in the original WK model) but also for some cases of $k > 1$, i.e., nonadjacent intervals. Moreover, in this account, intervals between the repetition of any particular response in successive cycles of the rhythm have variability related to the position in the hierarchy of the timer that triggers that response.

Both predictions received support in an analysis (Vorberg & Hambuch, 1984) of two-handed simultaneous responding. Two-handed tapping allowed the characteristics of M_j to be partialled out by using the between-hand interresponse interval cross-covariance function, $\text{ccov}((I, J)(k))$, to estimate multilevel timer properties. However, some cases of $\text{corr}(I_j, I_{j+k}) > 0$ were noted that were not predicted by the hierarchical timer model. To explain this, Vorberg and Wing (1996) introduced the concept of a rhythm program. In brief, this theory proposes that the successive elements of a rhythm have target durations determined by ratio relations between different hierarchical timing levels (and not as absolute times). Durations are set by a preparatory process that propagates a rate parameter down through the hierarchy (see Fig. 10; also, Krampe, Engbert, & Kliegl, 2001, this volume). The propagation introduces a pattern of positive correlations that reflects the propagation route down from higher to lower levels of the hierarchy. The positive correlations set up in preparing the rhythm are then modulated by the negative correlations arising in the hierarchical execution processes already discussed.

The production of rhythms with several intervals to be remembered and implemented might be expected to be more demanding on timing and memory than repeated production of a single interval. In a PET study (Penhune, Zatorre, & Evans, 1998) subjects listened to (or watched) and then reproduced short (6 s) isochronous and rhythm sequences by tapping with the R hand. Compared to a baseline listen-

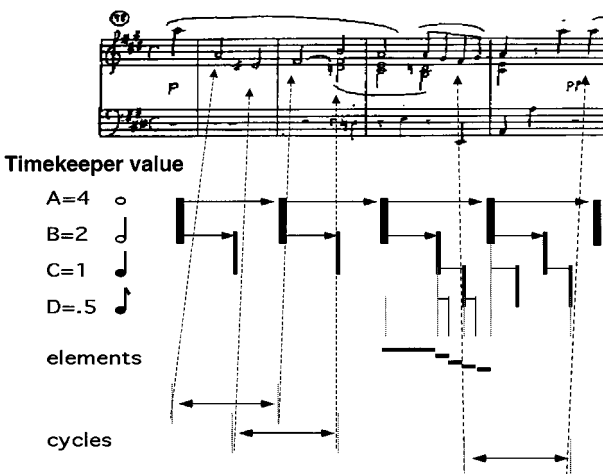

FIG. 9. Hierarchical timers proposed by Vorberg and Hambuch (1978) as an account of rhythm timing. Notes early in the bar (left) are identified with higher levels of the timing hierarchy than notes occurring late in the bar (right). Although the cycle duration between notes in equivalent positions in the bar is the same, the notes defined lower in the hierarchy involve a greater number of timekeeper elements and so have higher variance.

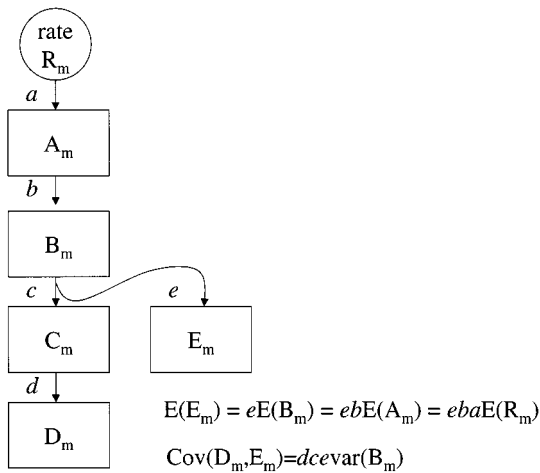

FIG. 10. Rhythm program model in which a rate parameter is used with proportional timing specification to set timer values at multiple levels in the hierarchy. (From Vorberg & Wing, 1996.)

only condition, producing isochronous intervals resulted in activation of contralateral sensorimotor region, globus pallidus, and ipsilateral anterior cerebellum in both visual and auditory conditions. Differences in activation between isochronous and prelearned rhythm sequences were limited to additional contralateral cerebellum in the visual condition. However, producing novel rhythms resulted in bilateral increases in cerebellar activation when compared to producing prelearned rhythms (in both vision and auditory conditions). This suggests a cerebellar role in learning rhythms.

In an fMR study of auditory rhythm production (Sakai et al., 1999) scans were taken just before right-hand reproduction of a rhythm heard 10 s previously. Compared to isochronous series, integer ratio rhythms showed increased activation of contralateral (L) premotor and parietal areas and ipsilateral anterior cerebellum. Non-integer ratio rhythms showed activation of ipsilateral (right) prefrontal, premotor, and parietal areas with bilateral posterior cerebellum. Psychophysical studies have suggested that noninteger ratios are represented as single intervals, whereas integer ratios involve a coherent relational representation (Povel & Essens, 1985). This led Sakai et al. to suggest that the different activation pattern may reflect greater demands made by noninteger ratios on working memory represented in right prefrontal cortex.

7. BIMANUAL TIMING

In many tasks, timing must be maintained across the two hands working together, as in the bimanual simultaneous tapping used by Vorberg and Hambuch (1984). It is important to consider the relation of bimanual to unimanual action. In the work cited earlier on cases of asymmetric basal ganglia or cerebellar dysfunction, different estimates of $\text{var}(C)$ were obtained for the two hands. In such cases producing simultaneous responses with both hands resulted in $\text{var}(C)$ estimates for each hand that converged on a single value (Wing et al., 1984; Franz, Ivry, & Helmuth, 1996). In normal subjects bimanual responding results in lower estimates of $\text{var}(C)$ compared to either hand tapping alone (Turvey, Rosenblum, Schmidt, & Kugler, 1986; Hulstijn, Summers, van Lieshout, & Peters, 1992; Helmuth & Ivry, 1996; see Table 4). Such effects suggest interactions between separate left and right timekeeping systems. Ivry

TABLE 4
Wing-Kristofferson Model Applied to Bimanual Timing with Each Hand Producing the Same Intervals^a

Ref.	Movement; manipulandum	T (ms)	Acorr(I(1))	Var(C) (ms ²)	Var(M) (ms ²)	Comment
1	Varying amplitude arm moves producing index finger presses; microswitch array	333	X	X	10 to 90	Simultaneous bimanual moves over equal or unequal distances show no evidence of hierarchy L-, R-hand interval cross-covariances used to estimate var(C)
2	Simultaneous bilateral rhythms (e.g., 2-4-2) vs isochronous (2-2-2-2) with finger; Morse key	1/8 note duration = 175; cycle duration = 1400	X	Rhythm 75 to 95; isochronous 29	23 to 29 21 to 25	For the same interval, between-hand intervals in AH tap more variable than SH
3	Index finger on single (SH) and alternate (AH) hands; touch key (force level)	100 (AH only); 200, 400, 800 (SH only)	-0.63 (100 ms); -0.12 (800 ms)	X	X	Out-of-phase pendulum resulted in larger var(C), var(M) unchanged
4	Bilateral wrist flex/extensions driving RH and LH pendula	900-1300 ms Pendula of equal/different length/mass moved in/out-of-phase	In-phase -0.25 Out-of-phase -0.20	Equal 400-100 Unequal 500-1800	100-450 200-500 (1900 with mass and length unequal)	Changing LH pendulum affected estimates of var(M) not var(C)
5	As (4) except out-of-phase only; RH pendulum length fixed, LH length varied	Combined period 604 to 1736	-1/2 < Acorr(I(1)) < 0 on 83% trials	1778	Increasing from 31 (at 604 ms) to 500 (at 1736 ms)	Similar values (including a bimanual advantage) for arm elevation
6	Unilateral (U); bilateral simultaneous (B); index finger; piano keys	400	X	(SD) U: 14 B: 10	(SD) 11 11	

Note: Refs. (1) Wing (1982); (2) Vorberg & Hambuch (1984); (3) Wing, Church, & Gentner (1989); (4) Turvey et al. (1986); (5) Turvey, Rosenblum, & Schmidt (1989); (6) Helmut & Ivry (1996).

^a X indicates no values reported.

and Richardson (2001, this volume) propose a specific mechanism for the interaction. They assume that timekeeping of a single hand is based on an activation accrual process (which could be based on a count of neural events, as in the model of Gibbon et al., 1984) with triggering of that hand's response when a predetermined threshold is attained. If, in bimanual tapping, the activation is summed across timekeepers for the two hands and, if the threshold is appropriately scaled, the same mean time will result but with lower variance.

If there are separate timing systems for each hand but their output is pooled prior to movement, the two-level timing model is applicable and, as already noted, this has been successfully exploited in the context of rhythm (Vorberg & Hambuch, 1984). However, if the goal is to produce equal intervals, but with L and R hands asynchronous rather than simultaneous, a different theoretical formulation is indicated. In tasks that require the two hands to tap out of phase, within-hand $\text{var}(I)$ is greater than estimates when the two hands tap in phase at the same rate (Yamanishi, Kawato, & Suzuki, 1980) and there can be spontaneous shifts into phase (Kelso, 1984). A seminal model of the phase shift phenomenon (Haken, Kelso, & Bunz, 1985) proposed that instability (increased $\text{var}(I)$) followed by phase transition results from two oscillatory effector systems (overt movement trajectories of each hand are modeled by limit cycle oscillators) that mutually influence one another. This influence is described by two coupling functions, with the function for one oscillator reflecting the current (or time-lagged) state of the other. While this model provides an account of phenomena, such as increased instability in out-of-phase tapping prior to switches to in-phase responding, a recently noted limitation is that predicted movement amplitude changes are not observed (Peper & Beek, 1998a, 1998b, 1999).

Anatomical studies of connectivity of motor cortex, premotor cortex, and SMA suggest a primary role of SMA (Rouiller et al., 1994) in coordinating bimanual action. SMA lesions in monkeys (Brinkman, 1981, 1984) and humans (Laplaine, Talairach, Meininger, Bancaud, & Orgogozo, 1977; Stephan et al., 1999) disrupt bimanually coordinated movement. In one case, a lesion of R SMA resulted in pathological mirror (in-phase) movements during bimanual coordination (Chan & Ross, 1988). In normals transcranial magnetic stimulation of SMA disrupts parallel (out-of-phase) repetitive finger movements and converts them to mirror (in-phase) movements (Pascual-Leone, Cohen, Wassermann, & Hallett, 1994). A PET analysis contrasting mirror and nonmirror bimanual movements showed greater activation of R SMA and dorsal premotor cortex during nonmirror movements (Sadato, Yonekura, Waki, Yamada, & Ishi, 1997).

With the two hands tapping at the same rate, at certain phase relations intermediate between alternation and synchrony, simple rhythmic patterns such as (1:2) or (1:3) may be defined by the between-hand intervals. More complex rhythmic patterns may be produced if the two hands tap regularly but with different periods that are not in simple integer relation to each other. Thus, for example, if the hands start in synchrony but one hand produces two intervals while the other produces three in the same time (e.g., the left hand taps at 300-ms intervals and the right hand at 200-ms) a between-hand pattern intervals (2:1:1:2) results. Three against four produces a pattern (3:1:2:2:1:3). Given that such polyrhythms involve periodic responding by each hand, it is interesting to ask whether control involves parallel independent timing by each hand (but with a link to keep in phase at the beginning of each cycle) (Table 5). When such parallel control is contrasted with integrated control tied to the (varying) between-hand subintervals within the cycle, the pattern of covariances observed between component intervals rejects the parallel model (Jagacinski, Marshburn, Klapp, & Jones, 1988; Summers, Rosenbaum, Burns, & Ford, 1993b; see Fig. 11).

TABLE 5
Wing-Kristofferson Model Applied to Bimanual Timing with Different Intervals in Either Hand (Polyrhythm)^a

Ref.	Movement; manipulandum	T (ms)	Accorr(I(1))	Var(C) (ms ²)	Var(M) (ms ²)	Comment
1	Bilateral 2 vs 3 poly- rhythm; Morse keys	LH 2 vs RH 3; cycle duration 1200 to 1400	X	(SD) 15	(SD) 8	Synchronization data treated as unpaced; interval correla- tions supported integrated multiplicative hierarchical model
2	Bilateral 3 vs 4 poly- rhythm; unspecified keys	Either 3 (600) or 4 (450) designated as ground (cycle duration 1800)	-1/2 < Accorr(I(1)) <0 on 85% trials	3-ground 88 to 134; 4-ground 57 to 104	6 to 52 18 to 42	Synchronization data treated as unpaced; structural equa- tion modeling supported multiplicative hierarchical timing
3	3 vs 4; RH300 vs LH400 (polyrhythm); RH(200, 400, 400, 200) vs LH400 (syncopated); piano keys	200, 300, or 400; cycle duration 600 to 2800	Sign. pos./neg. covars at fast tempos	X	LH 43; RH 30 (slower tempos)	Integrated timing (with rate fluctuation) at slow tempos; parallel control at fast tempos

Note: Refs. (1) Jagacinski et al. (1988); (2) Pressing, Summers, & Magill (1996); (3) Krampe et al. (2000).

^a X indicates no values reported.

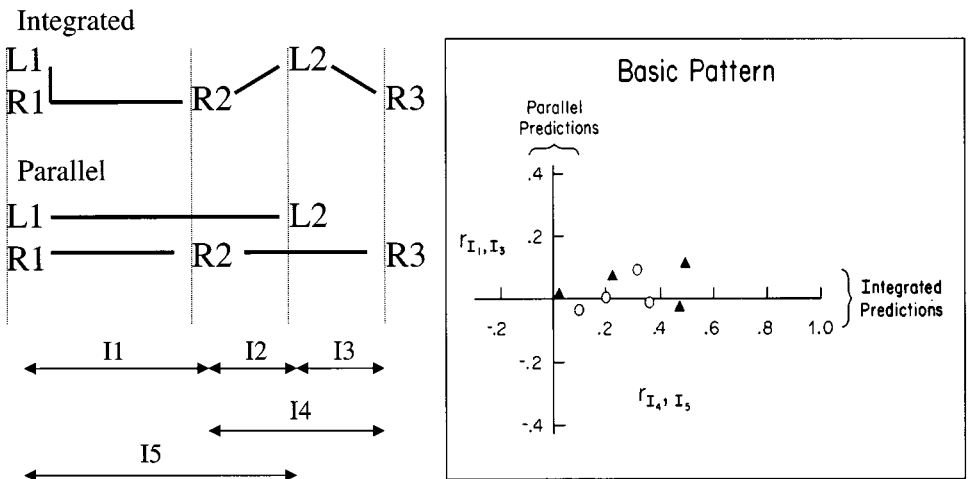

FIG. 11. Serial integrated vs parallel timing of 2 (LH) against 3 (RH) polyrhythm. (Left) Examples of integrated (above) and parallel (below) timing models. The integrated model predicts zero covariance between intervals $I1$ and $I3$ and positive covariance between intervals $I4$ and $I5$, whereas the parallel model predicts the opposite. (Right) Data from Jagacinski et al. (1988) favoring the integrated model.

This is true even after extensive practice (Summers, Ford, & Todd, 1993a; Summers & Kennedy, 1992; Klapp, Nelson, Jagacinski, 1998). However, an analysis of highly skilled keyboard performance has recently produced evidence for parallel timing when overall response rate is high (Krampe, Kliegl, Mayr, Engbert, & Vorberg, 2000).

8. DEFINITION OF THE RESPONSE

In this review of motor timing the emphasis has been on the performance of tasks in which timing is explicit. [Where timing is not an explicit task goal but is an emergent property there is evidence to suggest that different control structures apply (Robertson et al.; Zelaznik, Doffin, & Spencer, 2000).] Participants in experiments on explicit timing are invariably given clear instructions that their goal is to produce accurately timed responses. Since each trial usually begins with synchronization, there is little ambiguity about the definition of what constitutes a response. However, repeating a response implies a sequence of events after each response in order that the effector can be restored to a state that will allow the next response. For instance, flexing the finger to produce a tap, which the experimenter registers as a response, presumes a preceding phase in which the finger is extended. How should we conceptualize timing of other components in the cycle of activity in repetitive tapping?

Wing (1980b) suggested that there might be two timed elements in each cycle, one for flexion and one for extension. Conceivably, either could have been defined as a response, but with contact after flexion selected as the goal for synchronization, it seems reasonable to suppose that flexion would be explicitly timed and extension driven in a manner subordinate to flexion. Wing argued that extension might be triggered by contact via a feedback loop or, in open loop manner, by CNS commands for extension that are passed through a delay using a timekeeper at a lower level than the timekeeper responsible for successive flexion commands. That is, timing of different phases of movement might work in a hierarchical manner analogous to the hierarchy proposed for rhythm production by Vorberg and Hambuch (1978). However, an analysis of intervals between key contacts and releases rejected both of these

models. Instead Wing concluded that both flexion and extension were represented at the same level in the timing system.

The decomposition of the tapping cycle need not be restricted to just the two components, key contact and key release. Other points on a repeating finger movement cycle, in addition to—or instead of—contact and release, might be subject to timing. Indeed, under the WK model it might be supposed that it is not the tap itself but the onset of finger flexion, initiated when the finger is near the top of its trajectory, that represents the motor event triggered by the timekeeper. In which case the downward movement trajectory of the finger prior to contact would be viewed as contributing to the neuromuscular delay subsumed under the term motor implementation delay. Intervals between “responses” defined by flexion onset might therefore be less variable than intervals between the resulting taps. This possibility was examined and rejected by Billon and Semjen (1995). When they compared timing based on the onset of flexion with timing set by responses defined on contact at the end of the flexion phase, they found that contact times were less variable. Of course, it is possible that another point on the downward trajectory might be even less variable. For example, maximum acceleration is a movement parameter closely related to muscle recruitment and this might be the point in the movement cycle that is critically timed in the sense of being triggered by the timekeeper.

A limitation of the WK approach to timing, exposed by studies such as that of Billon and Semjen (1995), is that it treats continuous behavior as discrete. As a corollary the approach fails to account for intensive aspects of behavior and for possible interactions of the latter with timing. Yet, for example, it has been shown that requiring that one out of a series of equal force taps be accentuated results in local disturbances in timing (Billon, Semjen, & Stelmach, 1996). Because dynamical approaches to timing treat movement as continuous (an oscillation), they can, at least in principle, provide an account of the relations between timing (frequency) and amplitude. A limitation of oscillator accounts of timing has been noted (Daffertshoffer, 1998), that they do not predict the observed negative correlation between “responses” defined, for example, on one or other extreme of oscillatory motion. It is therefore interesting to note that Peper, Beek, and Daffertshoffer, (2000) have recently suggested that this may be remedied by using hierarchical oscillators at two levels, not unlike the two-level approach advocated by Wing and Kristofferson (1973b). However, such dynamical models have the disadvantage that their behavior is complex to predict and, in general, it is not possible to identify them uniquely from behavioral data.

9. SUMMARY

In summary I have shown the application of an information processing approach to human voluntary timing. The two-level WK account uses covariation of successive interresponse intervals in repetitive tapping to separate out variability arising in timekeeper and motor implementation functions. Experimental psychological studies have shown selective effects of factors on timekeeper or motor implementation variances. Neuropsychological studies of movement disorders associated with the cerebellum or basal ganglia have shown dissociation of variability of timekeeper and motor implementation. Data from brain activation studies show the importance of subcortical as well as cortical structures in timing simple, equal interval, and complex rhythmic patterns. Frontal cortical structures appear to be important in contributing to memory and attentional processes in timing which are particularly important in rhythms. Extensions to the WK model provide an account of variability in the production of unimanual and bimanual rhythmic timing patterns.

REFERENCES

- Billon, M., & Semjen, A. (1995). The timing of accent production in synchronization and continuation tasks performed by musicians and nonmusicians. *Psychological Research*, **58**, 206–217.
- Billon, M., Semjen, A., & Stelmach, G. E. (1996). The timing effects of accent production in periodic finger-tapping sequences. *Journal of Motor Behavior*, **28**, 198–210.
- Brinkman, C. (1981). Lesions in supplementary motor area interfere with a monkey's performance of a bimanual coordination task. *Neuroscience Letters*, **27**, 267–270.
- Brinkman, C. (1984). Supplementary motor area of the monkey's cerebral cortex: Short- and long-term deficits after unilateral ablation and the effects of subsequent callosal section. *Journal of Neuroscience*, **4**, 918–929.
- Chan, J.-L., & Ross, E.D. (1988). Left-handed mirror writing following right anterior cerebral artery infarction: Evidence for nonmirror transformation of motor programs by right supplementary motor area. *Neurology*, **38**, 59–63.
- Collins, C.J.S., Jahanshahi, M., & Barnes, G.R. (1998). Timing variability of repetitive saccadic eye movements. *Experimental Brain Research*, **120**, 325–334.
- Creelman, C.D. (1962). Human discrimination of auditory duration. *Journal of the Acoustical Society of America*, **34**, 582–593.
- Daffertshofer, A. (1998). Effects of noise on the phase dynamics of non-linear oscillators. *Physical Review E*, **58**, 327–338.
- Duchek, J. M., Balota, D. A., & Ferraro, F. R. (1994). Component analysis of a rhythmic finger tapping task in individuals with senile dementia of the alzheimer type and in individuals with parkinson's disease. *Neuropsychology*, **8**, 218–226.
- Franz, E. A., Ivry, R. B., & Helmuth, L. L. (1996). Reduced timing variability in patients with unilateral cerebellar lesions during bimanual movements. *Journal of Cognitive Neuroscience*, **8**, 107–118.
- Franz, E. A., Zelaznik, H. N., & Smith, A. (1992). Evidence of common timing processes in the control of manual, orofacial, and speech movements. *Journal of Motor Behavior*, **24**, 281–287.
- Gibbon, J. (1992). Ubiquity of scalar timing with a Poisson clock. *Journal of Mathematical Psychology*, **36**, 283–293.
- Gibbon, J., Church, R. M., & Meck, W. H. (1984). Scalar timing in memory. In J. Gibbon & L. Allan (Eds.), *Timing and time perception* (Vol. 423, pp. 52–77). New York: Academy of Sciences.
- Gibbon, J., Malapani, C., Dale, C. L., & Gallistel, C. R. (1997). Toward a neurobiology of temporal cognition: Advances and challenges. *Current Opinion in Neurobiology*, **7**, 170–184.
- Greene, L. S., & Williams, H. G. (1993). Age related differences in timing control of repetitive movement: Application of the Wing–Kristofferson model. *Research Quarterly of Exercise and Sports*, **64**, 32–38.
- Haken, H., Kelso, J. A. S., & Bunz, H. (1985). A theoretical model of phase transitions in human hand movements. *Biological Cybernetics*, **51**, 347–356.
- Harrington, D. L., & Haaland, K. Y. (1998). Sequencing and timing operations of the basal ganglia. In D. A. Rosenbaum & C. E. Collyer (Eds.), *Timing of behavior: Neural, psychological and computational perspectives* (pp. 35–61). Cambridge, MA: MIT Press.
- Harrington, D. L., Haaland, K. Y., & Hermanowicz, N. (1998a). Temporal processing in the basal ganglia. *Neuropsychology*, **12**, 3–12.
- Harrington, D. L., Haaland, K. Y., & Knight, R. T. (1998b). Cortical networks underlying mechanisms of time perception. *The Journal of Neuroscience*, **18**, 1085–1095.
- Helmuth, L. L., & Ivry, R. B. (1996). When two hands are better than one: Reduced timing variability during bimanual movements. *Journal of Experimental Psychology: Human Perception and Performance*, **22**, 278–293.
- Hulstijn, W., Summers, J. J., van Lieshout, P. H. M., & Peters, H. F. M. (1992). Timing in finger tapping and speech: A comparison between stutterers and fluent speakers. *Human Movement Science*, **11**, 113–124.
- Inhoff, A. W., & Bisiacchi, P. (1990). Unimanual tapping during concurrent articulation: Generalized and lateralized effects of memory encoding upon the rate and variability of concurrent finger tapping. *Brian and Cognition*, **6**, 24–40.
- Ivry, R., & Corcos, D. M. (1993). Slicing the variability pie: Component analysis of coordination and motor dysfunction. In K. M. Newell & D. M. Corcos (Eds.), *Variability and motor control* (pp. 415–447). Champaign, IL: Human Kinetics.
- Ivry, R., & Hazeltine, R. E. (1995). The perception and production of temporal intervals across a range

- of durations. *Journal of Experimental Psychology: Human Perception and Performance*, **21**, 1–12.
- Ivry, R., & Keele, S. (1989). Timing functions of the cerebellum. *Journal of Cognitive Neuroscience*, **1**, 136–152.
- Ivry, R., Keele, S., & Diener, H. C. (1988). Dissociation of the lateral and medial cerebellum in movement timing and movement execution. *Experimental Brain Research*, **73**, 167–180.
- Ivry, R. B., & Richardson, T. C. (2001). Temporal control and coordination: The multiple timer model. *Brain and Cognition*, doi:10.1006/brcg.2001.1308.
- Jagacinski, R. J., Marshburn, E., Klapp, S. T., & Jones, M. R. (1988). Tests of parallel versus integrated structure in polyrhythmic tapping. *Journal of Motor Behavior*, **20**, 416–442.
- Jahanshahi, M., Jenkins, I. H., Brown, R. G., Marsden, C. D., Passingham, R. E., & Brooks, D. J. (1995). Self-initiated versus externally triggered movements. I. An investigation using measurement of regional cerebral blood flow with PET and movement-related potentials in normal and Parkinson's disease subjects. *Brain*, **118**, 913–933.
- Keele, S., Pokorny, R., Corcos, D., & Ivry, R. (1985). Do perception and motor production share common timing mechanisms? A correlational analysis. *Acta Psychologica*, **60**, 173–191.
- Kelso, J. A. S. (1984). Phase transitions and critical behavior in human bimanual coordination. *American Journal of Physiology: Regulatory, Integrative and Comparative Physiology*, **15**, R1000–R1004.
- Klapp, S. T., Nelson, J. M., & Jagacinski, R. J. (1998). Can people tap concurrent bimanual rhythms independently? *Journal of Motor Behavior*, **30**, 301–322.
- Kooistra, L., Snijders, T. A., Schellekens, J. M., Kalverboer, A. F., & Geuze, R. H. (1997). Timing variability in children with early treated congenital hypothyroidism. *Acta Psychologica*, **96**, 61–73.
- Krampe, R. T., Engbert, R., & Kliegl, R. (2001). The effects of expertise and age on rhythm production: Adaptations to timing and sequence constraints. *Brain and Cognition*, doi:10.1006/brcg.2001.xxxx.
- Krampe, R. T., Kliegl, R., Mayr, U., Engbert, R., & Vorberg, D. (2000). The fast and slow of skilled bimanual rhythm production: parallel vs integrated timing. *Journal of Experimental Psychology: Human Perception and Performance*, **26**, 206–233.
- Laplante, D., Talairach, J., Meininger, V., Bancaud, J., & Orgogozo, J.M. (1977). Clinical consequences of corticectomies involving the supplementary motor area in man. *Journal of Neurological Sciences*, **34**, 301–314.
- Macar, F., Vidal, F., & Casini, L. (1999). The supplementary motor area in motor and sensory timing: Evidence from slow brain potential changes. *Experimental Brain Research*, **125**, 271–280.
- Madison, G. (2000). On the nature of variability in isochronous serial interval production. In P. Desain & L. Windsor (Eds.), *Rhythm perception and production*. Lisse, The Netherlands: Swets and Zeitlinger.
- Madison, G. (In press). Variability in isochronous tapping: Higher-order dependencies as a function of inter-tap interval. *Journal of Experimental Psychology: Human Perception and Performance*.
- Mangels, J. A., Ivry, R., & Shimuzu, N. (1998). Dissociable contributions of the prefrontal and neocerebellar cortex to time perception. *Cognitive Brain Research*, **7**, 15–39.
- Martin, J. G. (1972). Rhythmic (hierarchical) versus serial structure in speech and other behavior. *Psychology Review*, **79**, 487–509.
- Miall, C. (1996). Models of neural timing. In M. A. Pastor & J. Artieda (Eds.), *Time, internal clocks and movement*. Amsterdam: Elsevier Science.
- O'Boyle, D. J. (1997). On the human neuropsychology of timing of simple, repetitive movements. In C. M. Bradshaw & E. Szabadi (Eds.), *Time and behaviour. Psychological and neuro-behavioural analyses*. Amsterdam: Elsevier Press.
- O'Boyle, D. J., Freeman, J. S., & Cody, F. W. J. (1996). The accuracy and precision of timing of self-paced repetitive movements in subjects with Parkinson's disease. *Brain*, **119**, 51–70.
- Pascual-Leone, A., Cohen, L., Wassermann, E., & Hallett, M. (1994). The role of the supplementary motor area (SMA) in the coordination of bimanual movements. *Neurology*, **44**(Suppl. 2), A329.
- Pastor, M. A., Jahanshahi, M., Artieda, J., & Obeso, J. A. (1992). Performance of repetitive wrist movements in Parkinson's disease. *Brain*, **115**, 875–891.
- Penhune, V. B., Zatorre, R. J., & Evans, A. C. (1998). Cerebellar contributions to motor timing: A PET study of auditory and visual rhythm reproduction. *Journal of Cognitive Neuroscience*, **10**, 752–765.
- Peper, C. E., & Beek, P. J. (1998a). Are frequency-induced transitions in rhythmic coordination mediated by a drop in amplitude? *Biological Cybernetics*, **79**, 291–300.

- Peper, C. E., & Beek, P. J. (1998b). Distinguishing between the effects of frequency and amplitude on interlimb coupling in tapping a 2:3 polyrhythm. *Experimental Brain Research*, **118**, 78–92.
- Peper, C.E., & Beek, P. J. (1999). Modelling rhythmic interlimb coordination: The roles of movement amplitude and time delays. *Human Movement Science*, **18**, 263–280.
- Peper, C. E., Beek, P. J., & Daffertshofer, A. (2000). Considerations regarding a comprehensive model of (poly)rhythmic movements. In P. Desain & L. Windsor (Eds.), *Rhythm perception and production*. Lisse: Swets & Zeitlinger.
- Petrides, M., Alvisatos, B., Evans, A. C., & Meyer, E. (1993). Dissociation of human mid-dorsolateral from posterior dorsolateral frontal cortex in memory processing. *Proceedings of the National Academy of Sciences of the United States of America*, **90**, 873–877.
- Povel, D.J., & Essens, P. (1985). Perception of temporal patterns. *Music Perception*, **2**, 411–440.
- Pressing, J. (1999). The referential dynamics of cognition and action. *Psychological Review*, **106**, 714–747.
- Pressing, J., Summers, J., & Magill, J. (1996). Cognitive multiplicity in polyrhythmic pattern performance. *Journal of Experimental Psychology: Human Perception and Performance*, **22**, 1127–1148.
- Rao, S. M., Harrington, D. L., Haaland, K. Y., Bobholz, J. A., Cox, R. W., & Binder, J. R. (1997). Distributed neural systems underlying the timing of movements. *The Journal of Neuroscience*, **17**, 5528–5535.
- Robertson, S. D., Zelaznik, H. N., Lantero, D. A., Gadacz, K. E., Spencer, R. M., Doffin, J. G., & Schneidt, T. (1999). Correlations for timing consistency among tapping and drawing tasks: Evidence against a single timing process for motor control. *Journal of Experimental Psychology: Human Perception and Performance*, **25**, 1316–1330.
- Rosenbaum, D. A., & Patashnik, O. (1980a). A mental clock setting process revealed by reaction times. In G. E. Stelmach & J. Requin (Eds.), *Tutorials in motor behavior* (pp. 487–499). Amsterdam: North-Holland.
- Rosenbaum, D. A., & Patashnik, O. (1980b). Time to time in the human motor system. In R. S. Nickerson (Ed.), *Attention and performance* (Vol. 8). Hillsdale, NJ: Erlbaum.
- Rouiller, E. M., Balalian, A., Kazennikov, O., Moret, V., Yu, X.-H., & Wiesendanger, M. (1994). Transcallosal connections of the distal forelimb representation of the primary and supplementary motor cortical areas in macaque monkeys. *Experimental Brain Research*, **102**, 227–243.
- Sadato, N., Yonekura, Y., Waki, A., Yamada, H., & Ishi, Y. (1997). Role of the supplementary motor area and the right premotor cortex in the coordination of bimanual finger movements. *The Journal of Neuroscience*, **17**, 9667–9674.
- Saito, S., & Ishio, A. (1998). Rhythmic information in working memory: Effects of concurrent articulation on reproduction of rhythms. *Japanese Psychological Research*, **40**, 10–18.
- Sakai, K., Hikosaka, O., Miyauchi, S., Takino, R., Tamada, T., Iawata, N. K., & Nielsen, M. (1999). Neural representation of a rhythm depends on its interval ratio. *The Journal of Neuroscience*, **19**, 10074–10081.
- Semjen, A., Schulze, H.-H., & Vorberg, D. (2000). Timing precision in synchronisation and continuation tapping. *Psychological Research*, **63**, 137–147.
- Sergent, V., Hellige, J. B., & Cherry, B. (1993). Effects of responding hand and concurrent verbal processing on time-keeping and motor-implementation processes. *Brain and Cognition*, **23**, 243–262.
- Shaffer, L. H. (1982). Rhythm and timing in skill. *Psychology Review*, **89**, 109–122.
- Smyth, M. M., & Wing, A. M. (Eds.) (1984). *The psychology of human movement*. New York: Academic Press.
- Stephan, K. M., Binkofski, F., Halsband, U., Dohle, C., Wunderlich, G., Schnitzler, A., Tass, P., Posse, S., Herzog, H., Sturm, V., Zilles, K., Seitz, R.J., & Freund, H.J. (1999). The role of ventral medial wall motor areas in bimanual coordination. A combined lesion and activation study. *Brain*, **122**, 351–368.
- Stevens, L. T. (1886). On the time sense. *Mind*, **11**, 393–404.
- Summers, J. J., & Kennedy, T. M. (1992). Strategies in the production of 5:3 polyrhythm. *Human Movement Science*, **11**, 101–112.
- Summers, J. J., Rosenbaum, D. A., Burns, B. D., & Ford, S. K. (1993b). Production of polyrhythms. *Journal of Experimental Psychology: Human Perception and Performance*, 416–428.
- Summers, J. J., Ford, S. K., & Todd, J. A. (1993a). Practice effects on the coordination of the two hands in a bimanual tapping task. *Human Movement Science*, **11**, 101–112.

- Treisman, M. (1963). Temporal discrimination and the indifference interval: Implications for a model of the internal clock. *Psychological Monographs*, **77**, 13, Whole No 576.
- Treisman, M., Faulkner, A., Naish, P. L., & Brogan, D. (1990). The internal clock: Evidence for a temporal oscillator underlying time perception with some estimates of its characteristic frequency. *Perception*, **19**, 705–743.
- Turvey, M. T., Rosenblum, L. D., & Schmidt, R. C. (1989). Clock and motor components in absolute coordination of rhythmic movements. *Neuroscience*, **33**, 1–10.
- Turvey, M. T., Rosenblum, L. D., Schmidt, R. C., & Kugler, P. N. (1986). Fluctuations and phase symmetry in coordinated rhythmic movements. *Journal of Experimental Psychology: Human Perception and Performance*, **12**, 564–583.
- Vorberg, D., & Hambuch, R. (1978). On the temporal control of rhythmic performance. In J. Requin (Ed.), *Attention and performance* (pp. 535–555). Hillsdale, NJ: Erlbaum.
- Vorberg, D., & Hambuch, R. (1984). Timing of two-handed rhythmic performance. In J. Gibbon & L. Allan (Eds.), *Timing and time perception* (Vol. 423, 390–406). *New York Academy of Sciences*.
- Vorberg, D., & Wing, A. M. (1996). Linear and quasi-linear models of human timing behaviour. In H. Heuer & S. Keele (Eds.), *Human motor performance*. New York: Academic Press.
- Williams, H. G., Woollacott, M., & Ivry, R. (1992). Timing and motor control in clumsy children. *Journal of Motor Behavior*, **24**, 165–172.
- Wing, A. M. (1977). Effects of type of movement on the temporal precision of response sequences. *British Journal of Mathematical and Statistical Psychology*, **30**, 60–72.
- Wing, A. M. (1979). A note on estimation of the autocovariance function in the analysis of timing of repetitive responses. *British Journal of Mathematical and Statistical Psychology*, **32**, 143–145.
- Wing, A. M. (1980a). The long and short of timing in response sequences. In G. E. Stelmach & J. Requin (Eds.), *Tutorials in motor behaviour* (pp. 469–486). Amsterdam: North-Holland.
- Wing, A. M. (1980b). Timing of movement phases of a repeated response. *Journal of Motor Behavior*, **12**, 113–124.
- Wing, A. M. (1982). Timing and coordination of repetitive bimanual movements. *Quarterly Journal of Experimental Psychology*, **34**, 339–348.
- Wing, A. (1990). *The effect of cognitive load on the variability of isochronous and rhythmic tapping*. Paper presented at the 31st Annual Meeting of the Psychonomic Society, New Orleans, November 1990.
- Wing, A. M., & Beek, P. (In press). Movement timing: A tutorial. In W. Prinz & B. Hommel (Eds.), *Attention and performance* (Vol. 19).
- Wing, A. M., Church, R. M., & Gentner, D. R. (1989). Variability in the timing of responses during repetitive tapping with alternate hands. *Psychological Research*, **51**, 28–37.
- Wing, A. M., Keele, S. W., & Margolin, D. I. (1984). Motor disorder and the timing of repetitive movements. In J. Gibbon & L. Allan (Eds.), *Timing and time perception* (Vol. 423, pp. 183–192). *New York Academy of Sciences*.
- Wing, A. M., & Kristofferson, A. B. (1973a). The timing of interresponse intervals. *Perception and Psychophysics*, **13**, 455–460.
- Wing, A. M., & Kristofferson, A. B. (1973b). Response delays and the timing of discrete motor responses. *Perception and Psychophysics*, **14**, 5–12.
- Yamanishi, T., Kawato, M., & Suzuki, R. (1980). Two coupled oscillators as model for the coordinated finger tapping by both hands. *Biological Cybernetics*, **37**, 21–225.
- Zakay, D., & Bloch, R. A. (1996). The role of attention in time estimation processes. In M. A. Pastor & J. Artieda (Eds.), *Time, internal clocks and movement*. Elsevier Science.
- Zelaznik, H. N., Doffin, J. G., & Spencer, R. M. (2000). Temporal precision in tapping and circle drawing movements at preferred rates is not correlated: Further evidence against timing as a general-purpose ability. *Journal of Motor Behavior*, **32**, 193–199.